

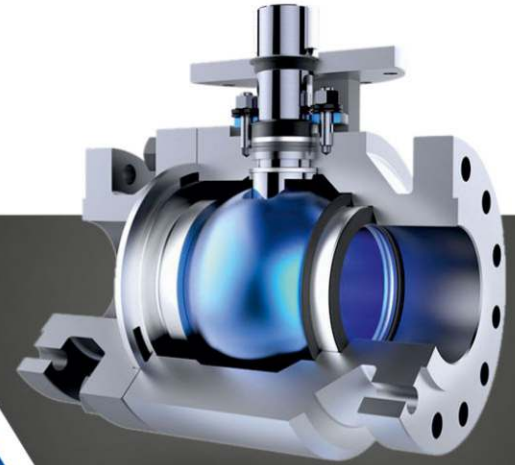

PCV
PAYAL NEW FLOW CONTROL VALVES



VALVES
FOR EVERY
INDUSTRY



www.payalvalves.com



PAYAL NEW FLOW CONTROL VALVES was found in 2023 in Hubballi, India with the purpose of providing a wide range of superior quality Valves with a goal to achieve the highest levels of perfection & excellence in the field of Valves with a core Engineering Focus. PNFCV manufactures Ball Valve, Gate Valves, Globe Valves, Check Valves & Butterfly Valves Catering to Oil, Gas, Petrochemicals, Power, Water Treatment and Steel, Sugar, Chemicals, Pharma Paper & Pulp Industries.

Sporting the most technologically advanced and versatile valve manufacturing units in the world through our high end CNC & VMC Machines and an abundance of skilled workforce. PAYAL NEW FLOW CONTROL VALVES has the ability to deliver the entire range of sizes and materials required by different industries.

OUR VISION

- To become a world-class leader in creating Unconventional design, manufacturer & delivery of quality Products
- Promoting a healthy environment to achieve industry best practices and set an even higher benchmark.
- Constantly thriving for the development of our high quality products while exceeding customer demands and requirements.
- We might become content with our achievement but never satisfied, rendering us to excel in the future of organizational development through our employees, suppliers and esteemed customers.

OUR MISSION

- Empowering global flow control.
- By realizing our true potential, at PAYAL NEW FLOW CONTROL VALVES we seize every opportunity to learn and outdo ourselves for a better tomorrow by putting our plans into action.
- To be the common economic entity among the companies requiring our valuable valves.
- To constantly deliver the top notch and excellent products.
- Instill confidence in our customers through our radically engineered designs through consent of our workforce and trusted users.

PCV CORE VALUES

Success is what comes of the integrated and unprecedented values. At PCV, We believe we are held together by the values that have driven us where we stand. We passionately live-up and unhold ten core values throughout our business and operations.





DESIGN STANDARD	TESTING STANDARD	TEST PRESSURE IN BAR	CLASS 150	CLASS 300	CLASS 600	CLASS 900	CLASS 1500
API 600 / ASME B 16.34	API 598 / EN 12266-1	HYDRO SHELL	30	78	153	230	383
END CONNECTIONS	Flanged Ends ASME B 16.5 Butt Weld Ends to ASME B 16.25	HYDRO SEAT & BACK SEAT	22	58	115	172	285
FACE TO FACE	ASME B 16.10	AIR SEAT	7	7	7	7	7

CLASS-150					CLASS -300				CLASS -600			
SIZE (DN/NPS)	A	B	ØC	WT (Kg) (Approx)	A	B	ØC	WT (Kg) (Approx)	A	B	ØC	WT (Kg) (Approx)
50 (2)	178	380	200	18	216	380	200	20	292	425	250	32
65 (2 1/2)	191	430	200	28	241	410	250	30	330	445	250	42
80 (3)	203	470	250	32	282	480	250	45	356	485	300	55
100 (4)	229	585	250	48	305	580	300	80	432	620	450	95
125 (5)	254	690	300	65	381	700	450	102	508	710	450	140
150 (6)	267	805	300	85	403	820	450	140	559	845	600	220
200 (8)	292	990	450	145	416	1020	450	230	660	1110	600	380
250 (10)	330	1230	450	220	457	1260	600	375	787	1135	750	605
300 (12)	356	1460	600	295	502	1500	600	480	838	1800	GEAR	830

CLASS -900							CLASS -1500						
SIZE (DN/NPS)	A		B	ØC	WT (Kg) (Approx)		Size (DN/NPS)	A		B	ØC	WT (Kg) (Approx)	
	FE	BWE			FE	BWE		FE	BWE				
50 (2)	368	216	480	300	60	45	50 (2)	368	216	480	300	60	45
65 (2 1/2)	419	254	560	450	85	60	65 (2 1/2)	419	254	560	450	85	60
80 (3)	381	305	650	750	125	85	80 (3)	470	305	630	600	120	70
100 (4)	457	356	650	750	165	105	100 (4)	546	406	650	750	165	130
125 (5)	559	432	850	GEAR	205	135	125 (5)	673	483	850	GEAR	290	195
150 (6)	610	508	1025	GEAR	340	210	150 (6)	705	559	1080	GEAR	446	285
200 (8)	737	660	1300	GEAR	590	428	200 (8)	832	711	1450	GEAR	881	570
250 (10)	838	787	1410	GEAR	795	655	250 (10)	991	864	1540	GEAR	1331	915
300 (12)	965	914	1625	GEAR	1120	870	300 (12)	1130	991	1635	GEAR	2530	1950

MATERIAL OF CONSTRUCTION	
Components	Materials
Body, Bonnet	ASTM A 216 Gr. WCB/ A217 WC6,WC9/ A351 CF8,CF8M,CF3,CF3M/ A352 LCB
Wedge, Seatring	ASTM A 216 Gr. WCB/ A217 WC6,WC9/ A351 CF8,CF8M,CF3,CF3M/ A352 LCB
Stem, Gland	ASTM A 276 Tp. SS410/SS304/SS316/SS304L/SS316L
Yoke/Sleeve	Ni - Resist ASTM A 439 Gr. D2
Packing	Grafoil/ Braided Graphite
Gasket	SPW SS 304 / 316 +Grafoil, SPW SS 304 / 316 + PTFE
Pressure Seal Ring	Moulded Grafoil
Fasteners	ASTM A 193 B7/B7M/B16/B8/B8M, A320 Gr. L7/ ASTM A 194 2H/2HM/8/8M/7
Handwheel	Malleable Iron / Carbon Steel

- All dimensions are in mm.
- Wedge & Seat ring shall be with stellite 6 if required for class 150, 300, 600 and is standard for class 900 & 1500.
- MOC, IBR, Cryogenic & other special requirements can be provided as per customer requirement.
- Due to continuous development we reserve the right to change the specification without notice.



DESIGN STANDARD	TESTING STANDARD	TEST PRESSURE IN BAR	CLASS 150	CLASS 300	CLASS 600	CLASS 900	CLASS 1500
API 600 / ASME B 16.34	API 598 / EN 12266-1	HYDRO SHELL	30	78	153	230	383
END CONNECTIONS	Flanged Ends ASME B 16.5 Butt Weld Ends to ASME B 16.25	HYDRO SEAT & BACK SEAT	22	58	115	172	285
FACE TO FACE	ASME B 16.10	AIR SEAT	7	7	7	7	7

CLASS-150					CLASS -300				CLASS - 600			
SIZE (DN/NPS)	A	B	ØC	WT (Kg) (Approx)	A	B	ØC	WT (Kg) (Approx)	A	B	ØC	WT (Kg) (Approx)
50 (2)	203	285	200	15	267	295	200	17	292	340	250	45
65 (2 1/2)	216	295	200	32	292	355	250	38	330	350	300	60
80 (3)	241	350	250	38	315	365	300	50	356	415	450	70
100 (4)	292	360	300	55	356	420	450	78	432	485	600	125
125 (5)	330	415	300	80	400	475	450	115	508	590	600	275
150 (6)	356	445	450	95	445	570	600	170	559	1025	GEAR	355
200 (8)	495	540	450	165	533	795	600	210	660	1165	GEAR	630
250 (10)	622	825	GEAR	250	622	1245	GEAR	460	787	1245	GEAR	855
300 (12)	698	905	GEAR	385	711	1440	GEAR	740	838	1340	GEAR	1035

CLASS -900							CLASS -1500						
SIZE (DN/NPS)	A		B	ØC	WT (Kg) (Approx)		SIZE (DN/NPS)	A		B	ØC	WT (Kg) (Approx)	
	FE	BWE			FE	BWE		FE	BWE				
50 (2)	368	216	565	300	82	55	50 (2)	368	216	480	300	82	62
65 (2 1/2)	419	254	578	450	95	60	65 (2 1/2)	419	254	560	450	95	85
80 (3)	381	305	590	500	100	65	80 (3)	470	305	630	500	115	100
100 (4)	457	356	699	GEAR	135	130	100 (4)	546	406	650	GEAR	235	135
125 (5)	559	432	1010	GEAR	230	210	125 (5)	673	483	850	GEAR	310	230
150 (6)	610	508	1150	GEAR	270	330	150 (6)	705	559	1110	GEAR	470	270
200 (8)	737	660	1230	GEAR	690	635	200 (8)	832	711	1205	GEAR	785	690
250 (10)	838	787	1348	GEAR	1310	830	250 (10)	991	864	1320	GEAR	1495	1310
300 (12)	965	914	1505	GEAR	1910	1725	300 (12)	1130	991	1435	GEAR	2310	1910

MATERIAL OF CONSTRUCTION	
Components	Materials
Body, Bonnet	ASTM A 216 Gr. WCB/ A217 WC6,WC9/ A351 CF8,CF8M,CF3,CF3M/ A352 LCB
Disc Seating	ASTM A 216 Gr. WCB/ A217 WC6,WC9/ A351 CF8,CF8M,CF3,CF3M/ A352 LCB
Stem, Gland	ASTM A 276 Tp. SS410/SS304/SS316/SS304L/SS316L
Yoke Bush	Ni - Resist ASTM A 439 Gr. D2
Packing	Grafoil/ Braided Graphite
Gasket	SPW SS 304 / 316 + Grafoil, SPW SS 304 / 316 + PTFE
Pressure Seal Ring	Moulded Grafoil
Fasteners	ASTM A 193 B7/B7M/B16/B8/B8M, A320 Gr. L7/ ASTM A 194 2H/2HM/8/8M/7
Handwheel	Malleable Iron / Carbon Steel

- All dimensions are in mm.
- Disc & Seat ring shall be with stellite 6 if required for class 150, 300, 600 and is standard for class 900 & 1500.
- MOC, IBR, Cryogenic & other special requirements can be provided as per customer requirement.
- Due to continuous development we reserve the right to change the specification without notice.

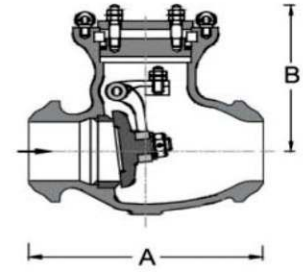
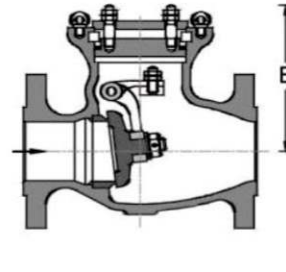
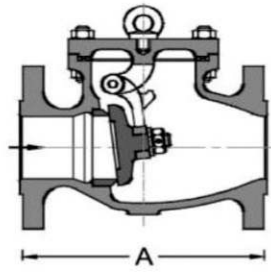

DESIGN STANDARD	TESTING STANDARD	TEST PRESSURE IN BAR	CLASS 150	CLASS 300	CLASS 600	CLASS 900	CLASS 1500
BS 1868 / ASME B 16.34	API 598 / EN 12266-1	HYDRO SHELL	30	78	153	230	383
END CONNECTIONS	Flanged Ends ASME B 16.5 Butt Weld Ends to ASME B 16.25	HYDRO SEAT	22	58	115	172	285
FACE TO FACE	ASME B 16.10						

CLASS- 150			
SIZE (DN/NPS)	A	B	WT (Kg) (Approx)
50 (2)	203	120	12
65 (2 1/2)	216	125	18
80 (3)	281	140	30
100 (4)	292	150	45
125 (5)	330	165	55
150 (6)	356	195	75
200 (8)	495	230	105
250 (10)	622	265	160
300 (12)	698	320	230

CLASS - 300		
A	B	WT (Kg) (Approx)
267	125	17
292	135	22
318	145	35
356	165	60
400	215	80
445	230	110
533	260	165
622	310	255
711	360	360

CLASS - 600		
A	B	WT (Kg) (Approx)
292	140	28
330	150	35
356	160	65
432	195	120
508	230	165
559	260	210
660	305	360
787	340	585
838	395	725

SIZE (DN/NPS)	CLASS - 900		B	WT (Kg) (Approx)	
	A	BWE		FE	BWE
50 (2)	368	216	185	55	32
65 (2 1/2)	419	254	190	65	35
80 (3)	381	305	240	98	37
100 (4)	457	356	260	115	42
125 (5)	559	432	315	140	70
150 (6)	610	508	330	245	95
200 (8)	737	660	470	485	220
250 (10)	838	787	540	755	235
300 (12)	965	914	635	1045	545

SIZE (DN/NPS)	CLASS - 1500		B	WT (Kg) (Approx)	
	A	BWE		FE	BWE
50 (2)	368	216	185	55	32
65 (2 1/2)	419	254	190	65	35
80 (3)	470	305	240	90	37
100 (4)	546	406	260	135	65
125 (5)	673	483	315	170	95
150 (6)	705	559	330	215	140
200 (8)	832	711	470	540	355
250 (10)	991	864	540	995	605
300 (12)	1130	991	635	1430	695

MATERIAL OF CONSTRUCTION	
Components	Materials
Body, Cover, Hinge, Bracket	ASTM A 216 Gr. WCB/ A217 WC6,WC9/ A351 CF8,CF8M,CF3,CF3M/ A352 LCB
Disc, Seat ring	ASTM A 216 Gr. WCB/ A217 WC6,WC9/ A351 CF8,CF8M,CF3,CF3M/ A352 LCB
Hinge Pin	ASTM A 276 Tp. SS410/SS304/SS316/SS304L/SS316L
Gasket	SPW SS 304 / 316 +Grafoil, SPW SS 304 / 316 + PTFE
Pressure Seal Ring	Moulded Grafoil
Fasteners	ASTM A 193 B7/B7M/B16/B8/B8M, A320 Gr. L7/ ASTM A 194 2H/2HM/8/8M/7

- All dimensions are in mm.
- Disc & Seat ring shall be with stellite 6 if required for class 150, 300, 600 and is standard for class 900 & 1500.
- MOC, IBR & other special requirements can be provided as per customer requirement.
- Due to continuous development we reserve the right to change the specification without notice.



Gate Valve

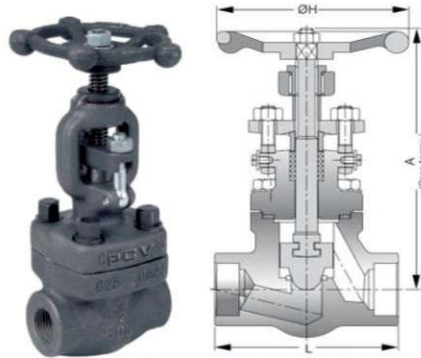

Globe Valve

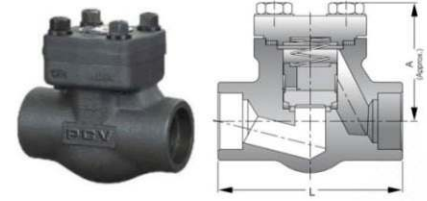

Lift Check Valve

DESIGN STANDARD	TESTING STANDARD	END CONNECTIONS	TEST PRESSURE IN BAR	CLASS 800	CLASS 1500
API 602	API 598	Screwed Ends to NPT (B 1.20.1), BSP, BSPT (BS 21)	HYDRO SHELL	205	383
EN ISO 15761	EN 12266-1	Socket Weld Ends to ASME B 16.11	HYDRO SEAT & BACK SEAT	152	285
ASME B 16.34		Butt Weld Ends to ASME B 16.25	AIR SEAT*	7	7

GATE VALVE - CLASS 800			
SIZE (DN/NPS)	L	A	ØH
15 (1/2)	85	154	110
20 (3/4)	91	162	110
25 (1)	103	233	110
32 (1 1/4)	128	233	170
40 (1 1/2)	128	233	170
50 (2)	142	240	170

GLOBE VALVE - CLASS 800			
SIZE (DN/NPS)	L	A	ØH
15 (1/2)	85	160	110
20 (3/4)	91	170	110
25 (1)	103	176	110
32 (1 1/4)	128	252	170
40 (1 1/2)	128	252	170
50 (2)	142	254	170

LIFT CHECK VALVE - CLASS 800		
SIZE (DN/NPS)	L	A
15 (1/2)	85	57
20 (3/4)	91	65
25 (1)	103	72
32 (1 1/4)	128	109
40 (1 1/2)	128	109
50 (2)	142	112

GATE VALVE - CLASS 1500			
(DN/NPS)	L	A	ØH
15 (1/2)	91	162	110
20 (3/4)	103	233	110
25 (1)	128	233	170
32 (1 1/4)	128	233	170
40 (1 1/2)	142	240	170

GLOBE VALVE - CLASS 1500			
SIZE (DN/NPS)	L	A	ØH
15 (1/2)	91	170	110
20 (3/4)	103	176	110
25 (1)	128	252	170
32 (1 1/4)	128	252	170
40 (1 1/2)	142	254	170

LIFT CHECK VALVE - CLASS 1500		
SIZE (DN/NPS)	L	A
15 (1/2)	91	65
20 (3/4)	103	72
25 (1)	128	109
32 (1 1/4)	128	109
40 (1 1/2)	142	112

MATERIAL OF CONSTRUCTION	
Components	Materials
Body, Bonnet, Cover & Gland Flange	ASTM A105/A182 Gr. F304, F316, F304L, F316L, F11, F22, A350 Gr. LF2
Wedge & Disc	ASTM A 217 Gr. CA15/ ASTM A 351 Gr. CF8/CF8M/CF3/CF3M
Stem, Seatring & Gland	ASTM A 276 Tp. SS410/SS304/SS316/SS304L/SS316L
Yoke Sleeve / Yoke Bush	S.G.Iron/Ni - Resist ASTM A 439 Gr. D2
Packing	Grafoil/ Braided Graphite
Gasket	SPW SS 304 / 316 + Grafoil, SPW SS 304 / 316 + PTFE
Spring	SS304/SS316
Fasteners	ASTM A 193 B7/B7M/B16/B8/B8M, A320 Gr. L7/ ASTM A 194 2H/2HM/8/8M/7
Handwheel	Malleable Iron / Carbon Steel

- All dimensions are in mm.
- Wedge, Disc & Seat rings shall be stellite 6 if required for class 800 and is standard for class 1500.
- Valves of class 1500 shall be with Welded Bonnet.
- Valves shall be supplied with welded flanges of class 150/300/600 if required.
- * Air Seat & back seat test not applicable for Lift Check Valves.
- MOC, IBR & other special requirements can be provided as per customer requirement.
- Due to continuous development we reserve the right to change the specification without notice.



Welded Flange End Valves

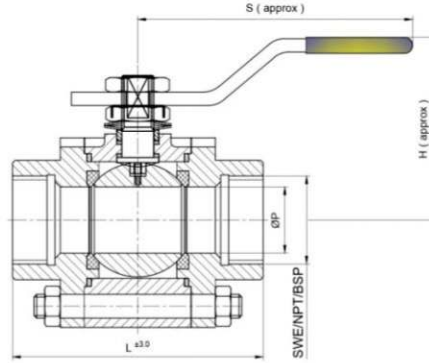

DESIGN STANDARD	TESTING STANDARD	TEST PRESSURE IN BAR	CLASS 150	CLASS 300	CLASS 600	CLASS 800
BS EN ISO 17292 / API 6D	API 598 / EN 12266-1	HYDRO SHELL	30	78	153	205
END CONNECTIONS	Socket Weld Ends to ASME B 16.11	HYDRO SEAT	22	58	69*	69*
	Screwed Ends to NPT [B 1.20.1], BSP,BSPT [BS 21]	AIR SEAT	7	7	7	7
	Butt Weld Ends to ASME B 16.25					

FULL BORE

SIZE [DN/NPS]	Ø P	L	H	S
15 [1/2]	13	67	70	120
20 [3/4]	17	76	76	120
25 [1]	24	86	87	170
40 [1 1/2]	38	116	117	250
50 [2]	49	130	125	250

REDUCED BORE

SIZE [DN/NPS]	Ø P	L	H	S
15 [1/2]	9	63	68	120
20 [3/4]	13	69	71	120
25 [1]	17	86	85	170
40 [1 1/2]	32	105	115	250
50 [2]	38	120	121	250

MATERIAL OF CONSTRUCTION

Components	Materials
Body, End Piece, Ball	ASTM A 216 Gr. WCB/ A351 Gr. CF8,CF8M,CF3,CF3M/ A995 Gr. 4A, 5A ASTM A105/A182 Gr. F304,F316,F304L,F316LF51,F55
Stem,Gland	ASTM A 276 Tp. SS410/SS304/SS316/SS304L/SS316L/UNS31803, 32750
Seat	PTFE, RPTFE, PEEK, DEVLON, NYLON, GFT, CFT
Packing	PTFE, GFT, GRAFOIL
Fasteners	ASTM A 193 B7/B7M/B16/B8/B8M, A320 Gr. L7/ ASTM A 194 2H/2HM/8/8M/7
Lever	CS+ Plated + PVC / SS + PVC

TECHNICAL SPECIFICATIONS FOR BALL VALVES

- Antistatic Design** : Sprint loaded steel balls are provided on stem and ball which gives continuity, thereby reducing the possibility of static electricity that build during operation when the ball rubs continuously on seat This can be potential fire hazard.
- Blowout Design** : EFVT design gives stem entry from inside while doing assembly which gives effective sealing just starting at the stem & at the same time collar prevents blow out of stem due to cavity pressure.
- Fire Safe Design** : In the design secondary metal to metal seat is provided, when the soft seat is burnt out or damaged during the fire. Balls us forced against the metal leap provided and hence forms a metal to metal seat
- Leakage Class** : No Leakage for soft seat [Class VI] / Meatl Seat [Class IV]

- All dimensions are in mm.
- MOC, Cryogenic & other special requirements can be provided as per customer requirement.
- * Valves will be tested at full pressure as per std for Peek & Metal Seat.
- Due to continuous development we reserve the right to change the specification without notice.

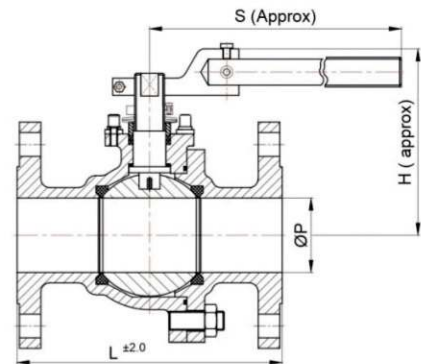
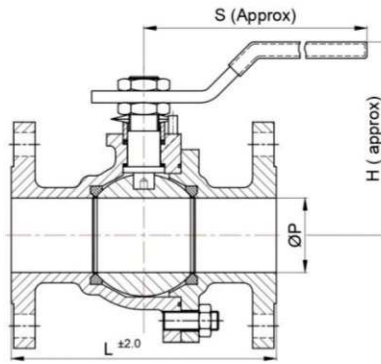

DESIGN STANDARD	TESTING STANDARD	END CONNECTIONS	FACE TO FACE	TEST PRESSURE IN BAR	CLASS 150	CLASS 300
BS ENISO 17292 API 6D	API 598 EN 12266-1	Flanged Ends ASME B 16.5	ASME B 16.10	HYDRO SHELL	30	78
		Butt Weld Ends to ASME B 16.25		HYDRO SEAT	22	58
				AIR SEAT	7	7

FULL BORE-CLASS 150

SIZE (DN/NPS)	Ø P	L	H	S
15 [1/2]	13	108	70	120
20 [3/4]	17	117	76	120
25 [1]	24	127	87	170
40 [1 1/2]	38	165	117	250
50 [2]	50	178	125	300
65 [2 1/2]	62	190	145	300
80 [3]	74	203	177	350
100 [4]	100	229	196	350
150 [6]	150	257	305	GEAR
200 [8]	201	292	350	GEAR

REDUCED BORE - CLASS 150

SIZE (DN/NPS)	Ø P	L	H	S
15 [1/2]	9	108	68	120
20 [3/4]	13	117	71	120
25 [1]	17	127	85	170
40 [1 1/2]	32	165	115	250
50 [2]	38	178	121	300
65 [2 1/2]	50	190	140	300
80 [3]	62	203	162	350
100 [4]	74	229	176	350
150 [6]	100	257	222	GEAR
200 [8]	150	292	320	GEAR

FULL BORE - CLASS 300

SIZE (DN/NPS)	Ø P	L	H	S
15 [1/2]	13	140	70	120
20 [3/4]	17	152	76	120
25 [1]	24	165	87	170
40 [1 1/2]	38	190	117	250
50 [2]	50	216	125	300
65 [2 1/2]	62	241	145	300
80 [3]	74	282	177	350
100 [4]	100	305	196	350
150 [6]	150	403	305	GEAR
200 [8]	201	419	350	GEAR

REDUCED BORE - CLASS 300

SIZE (DN/NPS)	Ø P	L	H	S
15 [1/2]	9	140	68	120
20 [3/4]	13	152	71	120
25 [1]	17	165	85	170
40 [1 1/2]	32	190	115	250
50 [2]	38	216	121	300
65 [2 1/2]	50	241	140	300
80 [3]	62	282	162	350
100 [4]	74	305	176	350
150 [6]	100	403	222	GEAR
200 [8]	150	419	320	GEAR

MATERIAL OF CONSTRUCTION

Components	Materials
Body, Tail Piece	ASTM A 216 Gr. WCB/ A351 Gr. CF8,CF8M,CF3,CF3M/ A995 Gr. 4A, 5A
Ball	ASTM A 216 Gr. WCB/ A351 Gr. CF8,CF8M,CF3,CF3M/ A995 Gr. 4A, 5A ASTM A105/A182 Gr. F304,F316,F304L,F316L,F51,F55
Stem,Gland	ASTM A 276 Tp. SS410/SS304/SS316/SS304L/SS316L/UNS31803, 32750
Seat	PTFE,RPTFE, PEEK, DEVLON, NYLON, GFT, CFT
Packing	PTFE, GFT, GRAFOIL
Fasteners	ASTM A 193 B7/B7M/B16/B8/B8M, A320 Gr. L7/ ASTM A 194 2H/2HM/8/8M/7
Lever	CS+ Plated + PVC / SS + PVC

- All dimensions are in mm.
- Valves upto 100FB are Lever Operated
- MOC, Cryogenic & other special requirements can be provided as per customer requirement.
- All size valves can be provided with Gear, Pneumatic Actuator & Motor Operated.

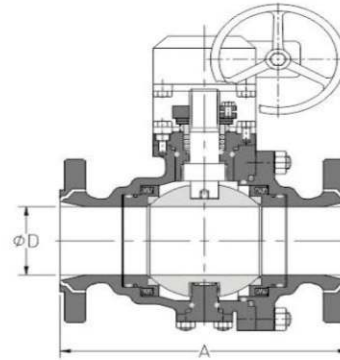

DESIGN STANDARD	TESTING STANDARD	END CONNECTIONS	FACE TO FACE	TEST PRESSURE IN BAR	CLASS 150	CLASS 300	CLASS 600
BS ENISO 17292 API 6D	API 598 EN 12266-1	Flanged Ends ASME B 16.5	ASME B 16.10	HYDRO SHELL	30	78	153
		Butt Weld Ends to ASME B 16.25		HYDRO SEAT	22	58	69*
				AIR SEAT	7	7	7

SIZE (DN/NPS)	Ø D		CLASS- 150				CLASS-300				CLASS-600			
			A		WT (Kg) [Approx]		A		WT (Kg) [Approx]		A		WT (Kg) [Approx]	
	FB	RB	FE	BWE	FB	RB	FE	BWE	FB	RB	FE	BWE	FB	RB
50 [2]	50	38	--	--	--	--	--	--	--	--	292	292	35	22
65 [2 1/2]	62	50	--	--	--	--	--	--	--	--	330	330	50	38
80 [3]	74	62	--	--	--	--	--	--	--	--	356	356	68	49
100 [4]	100	74	--	--	--	--	--	--	--	--	432	432	135	93
150 [6]	150	100	394	457	120	65	403	457	178	110	559	559	298	178
200 [8]	201	150	457	521	195	130	502	521	280	205	660	660	438	345
250 [10]	252	201	533	559	280	205	568	559	428	345	787	787	760	555
300 [12]	303	252	610	635	380	260	648	635	520	488	838	838	955	830

FE - Flanged End, BWE- Butt Weld End, FB - Full Bore, RB - Reduced Bore

MATERIAL OF CONSTRUCTION	
Components	Materials
Body, Tail Piece	ASTM A 216 Gr. WCB/ A351 Gr. CF8,CF8M,CF3,CF3M/ A995 Gr. 4A, 5A
Ball, Trunnion	ASTM A 216 Gr. WCB/ A351 Gr. CF8,CF8M,CF3,CF3M/ A995 Gr. 4A, 5A
Stem, Gland	ASTM A 276 Tp. SS410/SS304/SS316/SS304L/SS316L/UNS 303, 32750
Seat	PTFE, RPTFE, PEEK, DEVLON, NYLON, GFT, CFT
Seat Retainer	ASTM A 216 Gr. WCB/ A351 Gr. CF8,CF8M,CF3,CF3M/ A995 Gr. 4A, 5A
Coil Spring	INCONEL X - 750
Body Seal	SPW SS 304 / SS 316 + GRAFOIL, PTFE
Packing	PTFE, GFT, GRAFOIL
Trunnion Bearing	SS+ PTFE
Fasteners	ASTM A 193 B7/B7M/B16/B8/B8M, A320 Gr. L7/ ASTM A 194 2H/2HM/8/8M/7
Lever / Gear Box	CS+ Plated + PVC , SS + PVC / STD

- All dimensions are in mm.
- Valves upto 100FB are Lever Operated
- MOC, Cryogenic & other special requirements can be provided as per customer requirement.
- * Valves will be tested at full pressure as per std for Peek & Metal Seat.
- All size valves can be provided with Gear, Pneumatic Actuator & Motor Operated.
- Lifting point will be provided for DN150 and above.
- Due to continuous development we reserve the right to change the specification without notice.

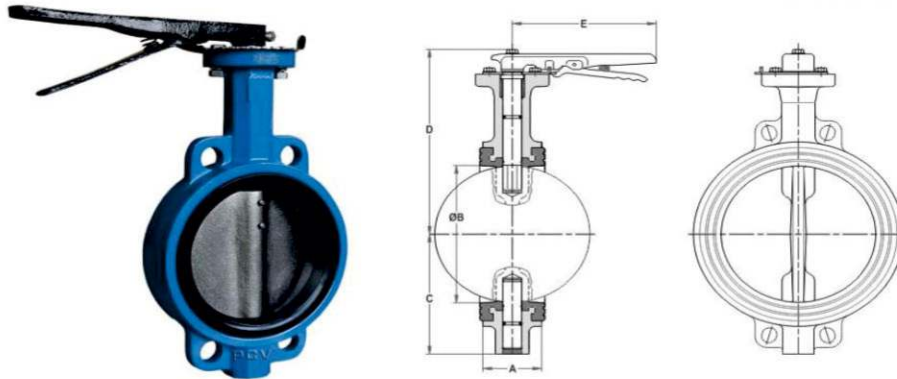

DESIGN STANDARD	TESTING STANDARD	TEST PRESSURE IN BAR	PN 10	PN 16
BS EN 593 / API 609	API 598 / BS EN 12266 - 1	HYDRO SHELL	15	24
		SEAT	11	18

SIZE (DN/NPS)	A	Ø B	C	D	E	WT (Kg) (Approx)
50 (2)	43	50	65	135	260	2.5
65 (2 1/2)	46	65	70	155	260	3
80 (3)	46	76	80	160	260	4
100 (4)	52	100	95	180	260	5.5
125 (5)	56	125	110	210	260	6.5
150 (6)	56	150	125	215	260	7.5
200 (8)	60	200	160	400	Gear	18
250 (10)	68	250	200	465	Gear	27
300 (12)	78	300	225	510	Gear	36

MATERIAL OF CONSTRUCTION

Components	Materials
Body	CI (IS:210 FG-220, 260) / ASTM A 216 Gr. WCB/ A351 Gr. CF8,CF8M,CF3,CF3M
Disc	SGI, DI, ASTM A 216 Gr. WCB/ A351 Gr. CF8,CF8M,CF3,CF3M
Seat	EPDM, NITRILE
Stem	ASTM A 276 Tp. SS410/SS304/SS316/SS304L/SS316L
O Ring	NITRILE
Lever / Gear Box	SPW SS 304 / SS 316 + GRAFOIL, PTFE

- All dimensions are in mm.
- MOC, & other special requirements can be provided as per customer requirement.
- All size valves can be provided with Pneumatic Actuator & Motor Operated.

Needle Valve

DESIGN STANDARD	TESTING STANDARD	END CONNECTIONS	TESTING PRESSURE IN BAR	CLASS 800
Mfg. Std / BS 5352	API 598 / EN 12266-1	Screwed Ends to NPT [B 1.20.1], BSP,BSPT [BS 21]	HYDRO SHELL	205
		Socket Weld Ends to ASME B 16.11	HYDRO SEAT & BACK SEAT	152
			AIR SEAT	7

SIZE (DN/NPS)	A	L	H	MATERIAL OF CONSTRUCTION	
6 (1/4)	SWE / BSP / NPT	50	75	Components	Materials
10 (3/8)	SWE / BSP / NPT	50	75	Body, Bonnet	A105/SS410/304/316
15 (1/2)	SWE / BSP / NPT	58	90	Gland, Gland Nut	SS410/304/316
20 (3/4)	SWE / BSP / NPT	70	100	Spindle	SS410/304/316
25 (1)	SWE / BSP / NPT	75	108	Packing	PTFE, GRAFOIL
40 (1 1/2)	SWE / BSP / NPT	80	110		



WAFER TYPE CHECK VALVE & NON SLAM CHECK VALVE

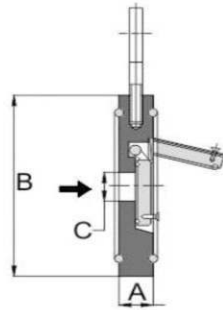

Wafer Check Valve

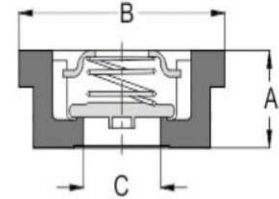

Non Slam Check Valve

	WAFER CHECK VALVE	NON SLAM CHECK VALVE	TEST PRESSURE IN BAR	PN 10	PN 16	CLASS 150	CLASS 300
DESIGN STD	API 594 / API 6D	MFG. STD	HYDRO SHELL	15	24	30	78
TESTING STD	API 598	API 598	HYDRO SEAT	11	18	22	58

Wafer Check Valve

Non Slam Check Valve

SIZE (DN/NPS)	A		Ø B				C	SIZE (DN/NPS)	A	B	Ø C
	CLASS 150	CLASS 300	PN 10	PN 16	CLASS 150	CLASS 300					
15 [1/2]	--	--	--	--	--	--	--	15 [1/2]	17	42	15
20 [3/4]	--	--	--	--	--	--	--	20 [3/4]	20	52	19
25 [1]	--	--	--	--	--	--	--	25 [1]	23	63	25
40 [1 1/2]	19	19	94	94	85	95	20	40 [1 1/2]	32	85	40
50 [2]	19	19	109	109	105	111	30	50 [2]	40	95	50
65 [2 1/2]	19	19	129	129	124	130	40	65 [2 1/2]	46	115	65
80 [3]	19	19	144	144	137	149	52	80 [3]	50	133	80
100 [4]	19	19	164	164	175	180	71.5	100 [4]	60	154	100
150 [6]	19	22	220	220	222	250	114	150 [6]	105	222	150
200 [8]	29	29	275	275	279	307	157	200 [8]	140	291	200
250 [10]	29	38	330	331	340	362	195	250 [10]	200	329	250
300 [12]	38	51	380	386	410	422	240	300 [12]	250	380	300

MATERIAL OF CONSTRUCTION

Components	Materials
Body	ASTM A 216 Gr. WCB/ A351 Gr. CF8,CF8M,CF3,CF3M
Disc	ASTM A 216 Gr. WCB/ A351 Gr. CF8,CF8M,CF3,CF3M ASTM A 276 Tp. SS410/SS304/SS316/SS304L/SS316L
Sealing Seat	EPDM, PTFE
Spring / Guide Plate	SS304 / SS316
EyeBolt	Carbon Steel / Stainless Steel
Button	SS304 / SS316

- All dimensions are in mm.
- MOC & other special requirements can be provided as per customer requirement.
- Non Slam Check Valve seat shall be integral.
- Valves can be supplied to suit ASME / BS / DIN / Flanges.
- Due to continuous development we reserve the right to change the specification without notice.

INDUSTRIES SERVED

Oil & Gas

Petroleum Refineries

Equipment Mfgr's

Pharmaceuticals

Power Plants

Boiler Mfgr's

Sewage Treatment

Textile Industry

Water treatment

Steel & Allied Industry

Chemical Industry

Sugar Industry, Many more...



PAYAL NEW FLOW CONTROL VALVES

B-59, 11th Main, KSSIDC Industrial Area,
Gamanagatti, HUBBALLI - 580025. Cell : +91 83810 91936

www.payalvalves.com

E-mail : payalvalves@gmail.com

